

TECHNICAL NOTE

Field Notching and Drilling of Glued Laminated Timber Beams

Number S560J
February 2020

Introduction

Glued laminated timber (glulam) beams are highly engineered components manufactured from specially selected and positioned lumber laminations of varying strength and stiffness. These fabricated beams are often specified where a certain span, strength and/or stiffness is required. As such, glulam beams are generally designed for and used in applications where they will be highly stressed under design loads. Whenever making field modifications such as notching, tapering or drilling not shown on the design or shop drawings, always follow the guideline provided in this document or consult the engineer of record before making the modifications.

As mentioned above, glulam beams are fabricated using selected lumber laminations of various strength, stiffness and species. The beams are “assembled” with lower grade material in the mid-depth of the beam and higher grade material positioned on the top and bottom. The highest grade of material is used as the outermost laminations on the tension side of the beam. Because of this, any drilling, dapping or notching that takes place in these outermost tension laminations has effects on the strength and serviceability of the beam. First, such modifications reduce the section of the beam. Second, they remove wood fiber from the laminations having the highest strength. In addition, stress concentrations may occur in areas modified by notching or drilling.

This Technical Note provides prescriptive recommendations for field notching, tapering and drilling glulam beams. Beams illustrated herein are assumed to be simple span subjected to uniform loads, and are shown with the compression side up. All equations and notching guidelines are presented using the same assumptions. If this information is applied to continuous or cantilevered beams, it should be used with extreme caution and only based on rational engineering analyses.

It is important to understand that improperly made field notches or holes may reduce the capacity of a properly designed member, possibly causing structural failure. The effects of any field notching or drilling should be checked by a designer competent in engineered timber design.

Notching

Notching of bending members should be avoided whenever possible, especially on the tension side of a member. Tension-side notching of glulam beams is not permitted except at end bearings and then only under specific conditions. The notching of a bending member on the tension side results in a decrease in strength caused by stress concentrations which develop around the notch, as well as a reduction of the area resisting the bending and shear forces. Such notches induce perpendicular-to-grain tension stresses which, in conjunction with horizontal shear forces, can cause splitting along the grain, typically starting at the inside corner of the notch. Stress concentrations due to notches can be reduced by using a gradually tapered notch configuration in lieu of a square-cornered notch. Rounding the square corner of a notch with a radius of approximately 1/2 inch is also recommended to reduce stress concentrations in these areas.

For square-cornered notches occurring at the ends of beams on the tension side, the designer may consider the use of reinforcement, such as full-threaded lag screws, to resist the tendency to split at the notch (See Figure 1). A number of design methodologies exist for sizing such screws. The design methodology selected and subsequent fabrication

details are the responsibility of the designer/engineer of record. If lag screws are used, lead holes shall be predrilled in accordance with accepted practice. This procedure can also be used as a field remedy to minimize further propagation of an existing crack.

Where glulam members are notched at the ends for bearing over a support, the notch depth shall not exceed 1/10 of the beam depth. Figure 2(e) is provided to assist in evaluating the associated reductions to beam strength due to notching on the tension side. For notches on the compression side, a less severe condition exists and equations for the analysis of the effects of these notches are also given in Figure 2. The equations given are empirical in nature and were developed for the conditions shown.

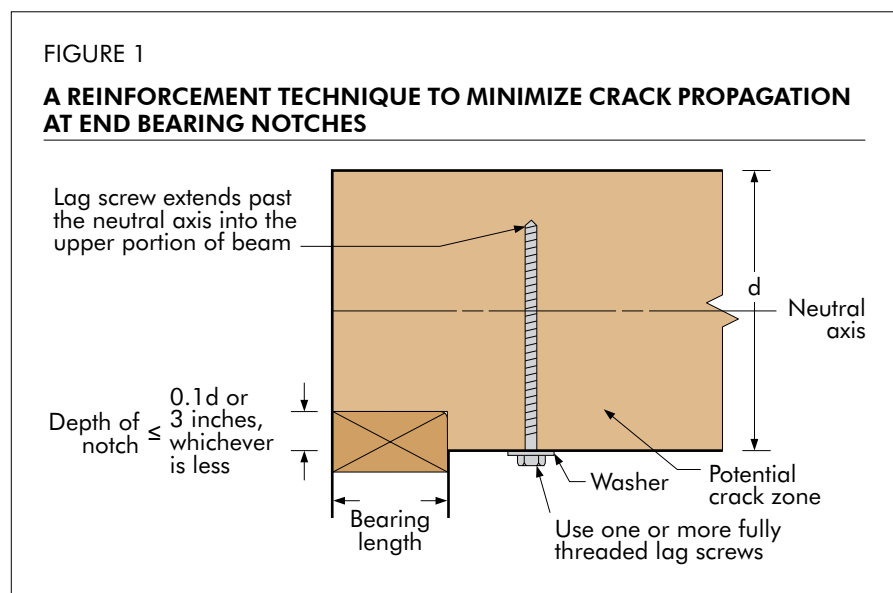
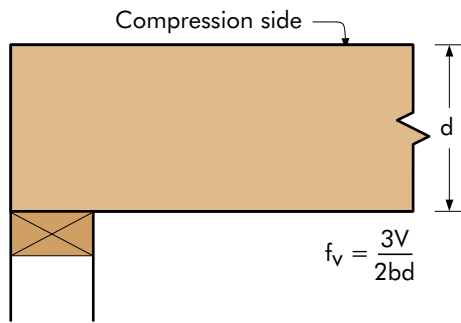
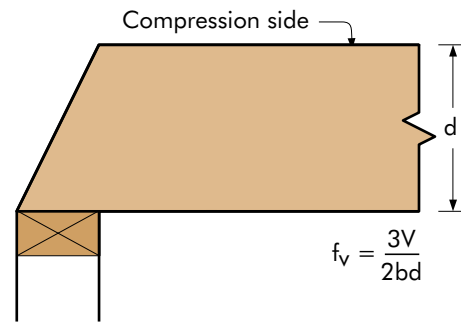

FIGURE 2

SHEAR DESIGN EQUATIONS FOR NOTCHED AND TAPERED BEAMS



(a) Square End Bearing



(b) Slope End Bearing

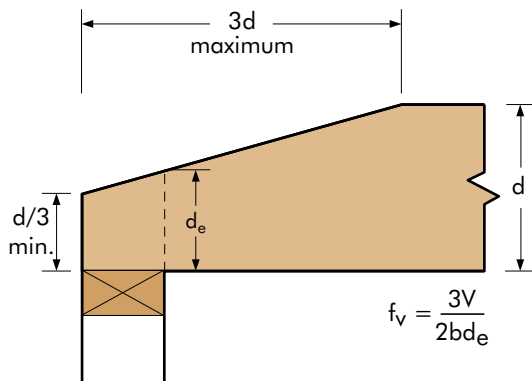

(c) Sloped End Cut for Roof Drainage

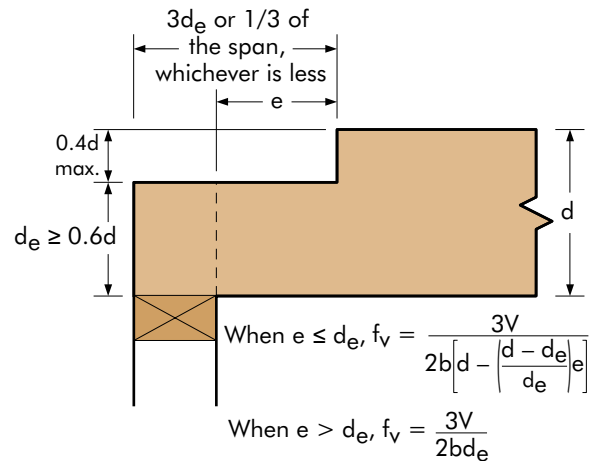

(d) Compression-side Notch

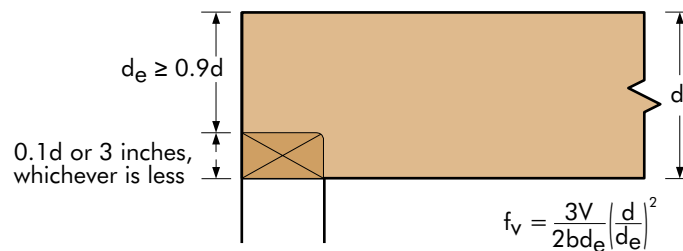

(e) Tension-side Notch

f_v = shear stress (psi) V = shear force at notch location (lb) b = width of beam (in.)
 d = depth of beam (in.) d_e = effective depth as shown (in.) e = length of notch as shown (in.)

As this guideline is limited to single span, simply supported beams, the notches shown in Figure 2 occur in areas of high shear and effectively zero moment. For this reason, the design equations given are shear equations. In situations where compression side notches extend into areas of significant moment, the bending capacity of the beam should also be checked using the remaining section of the beam and the appropriate allowable stresses for those laminations remaining at the notch location.

When it becomes necessary to cut a small notch in the top of a glued laminated timber (in the compression zone) to provide passage for small diameter pipe or conduit, this cut should be made in areas of the beam stressed to less than 50% of the design bending stress. The net section in these areas should be checked for shear and bending stresses to ensure adequate performance.

All field notches should be accurately cut. Avoid over-cutting at the root of the notch. Drilling a pilot hole in the member at the interior corner location of a notch as a stop point for the saw blade provides both a rounded corner and minimizes over-cutting at the corner.

Holes

Horizontal Holes

Like notches, holes in a glulam beam remove wood fiber, thus reducing the net area of the beam at the hole location and introducing stress concentrations. These effects cause a reduction in the capacity of the beam in the area of the penetration. For this reason, horizontal holes in glued laminated timbers are limited in size and location to maintain the structural integrity of the beam. Figure 3 shows the zones of a uniformly loaded, simply supported beam where the field drilling of holes may be considered. These non-critical zones are located in portions of the beam stressed to less than 50% of design bending stress and less than 50% of design shear stress. For beams of more complex loading or other than simple spans, similar diagrams may be developed. APA Technical Note, *Effect of Large Diameter Horizontal Holes on the Bending and Shear Properties of Structural Glued Laminated Timber*, Form V700, provides additional engineering guidelines where larger horizontal holes than those specified in this document cannot be avoided in design.

Field-drilled horizontal holes should be used for access only and should not be used as attachment points for brackets or other load bearing hardware unless specifically designed as such by the engineer or designer. Examples of access holes include those used for the passage of wires, electrical conduit, small diameter sprinkler pipes, fiber optic cables, and other small, lightweight materials. These field drilled horizontal holes should meet the following guidelines:

1. Hole size: The hole diameter should not exceed 1-1/2 inches or 1/10 the beam depth, whichever is smaller, with the exception of 1-inch-diameter or smaller holes as noted in Item 2 below.

2. Hole location: The hole should have a minimum clear distance, as measured from the edge of the hole to the nearest edge of the beam, of four hole diameters to the top or bottom face of the beam and eight hole diameters from the end of the beam. Note that the horizontal hole should not be drilled in the moment-critical zone, as defined in Figure 3, unless approved by an engineer or architect qualified in engineered timber design.

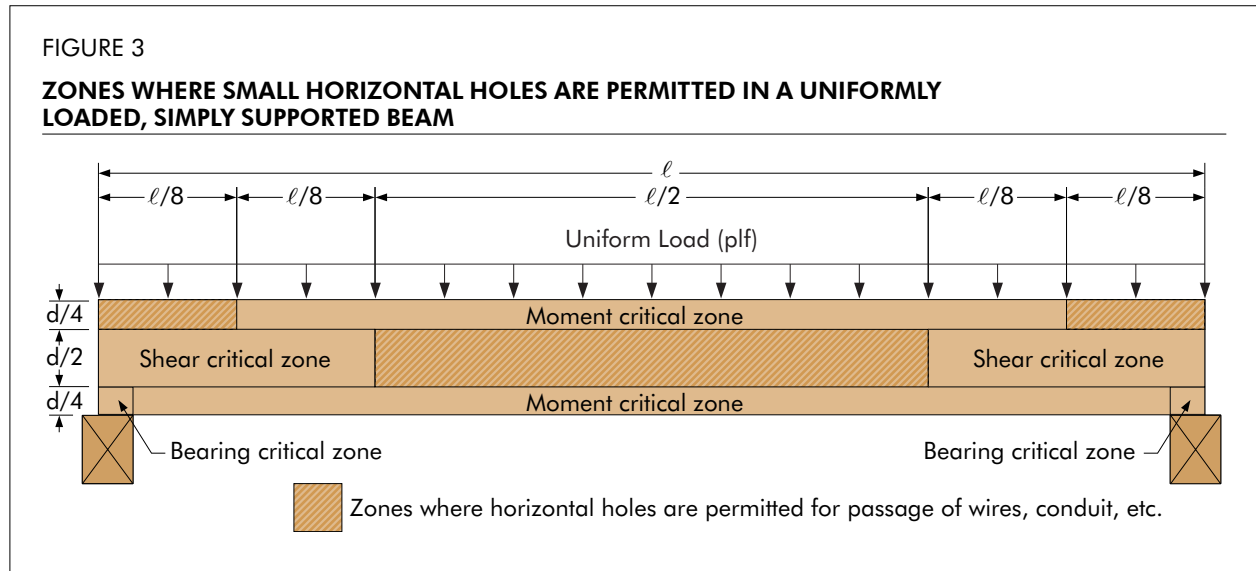

A 1-inch-diameter or smaller hole may be cut at the middle half of the beam depth anywhere along the span, except for the area that is within 6 inches of clear distance between the face of the support and the nearest edge of the hole (see Figure 4), provided the following conditions are all met:

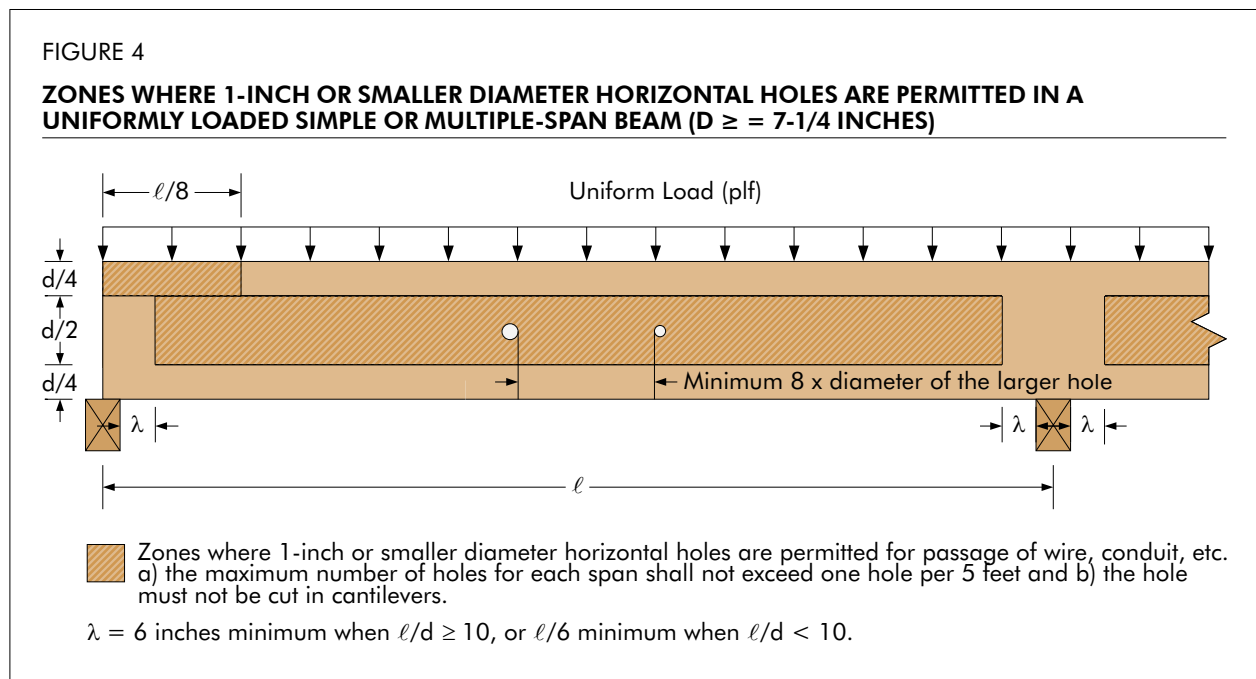

- a. the beam is at least 7-1/4 inches in depth,
- b. the beam is subject to uniform loads only,
- c. the span-to-depth ratio (ℓ/d) is at least 10,
- d. the hole spacing and maximum number of holes must meet the requirements specified in Items 3 and 4 below, and
- e. the hole must not be cut in cantilevers.

If the span-to-depth ratio of the beam is less than 10, the 1-inch diameter or smaller hole may be cut in accordance with the provisions listed above except that the location of the hole must maintain a clear distance between the face of the support and the nearest edge of the hole of at least 1/6 of the span.

3. Hole spacing: The minimum clear spacing between adjacent holes, as measured between the nearest edge of the holes, should be eight hole diameters based on the largest diameter of any adjacent hole in the beam.

4. Number of holes: The maximum number of holes should not exceed one hole per 5 feet of beam length. In other words, the maximum number of holes should not exceed four for a 20-foot-long beam. The hole spacing limitation, as given above, should be satisfied separately.

For glulam members that have been oversized, the guidelines given above may be relaxed based on an engineering analysis.

Regardless of the hole location, holes drilled horizontally through a member should be positioned and sized with the understanding that the beam will deflect over a period of time under in-service loading conditions. This deflection could cause distress to supported equipment or piping unless properly considered.

Vertical Holes

Whenever possible, avoid drilling vertical holes through glulam beams. As a rule of thumb, vertical holes drilled through the depth of a glulam beam cause a reduction in the capacity at that location directly proportional to the ratio of 1-1/2 times the diameter of the hole to the width of the beam.

For example, a 1-inch hole drilled in a 6-inch-wide beam would reduce the capacity of the beam at that section by approximately $\frac{(1 \times 1-1/2)}{6} = 25\%$.

Beam depth, d (in.)	Span when $\ell/d = 10$
7-1/4	6'-1"
7-1/2	6'-3"
8-1/4	6'-11"
9	7'-6"
9-1/4	7'-9"
9-1/2	7'-11"
9-5/8	8'-1"
10-1/2	8'-9"
11	9'-2"
11-1/4	9'-5"
11-7/8	9'-11"
12	10'-0"
12-3/8	10'-4"
13-1/2	11'-3"
14	11'-8"
15	12'-6"
15-1/8	12'-8"
16	13'-4"
16-1/2	13'-9"
17-7/8	14'-11"
18	15'-0"
19-1/4	16'-1"
19-1/2	16'-3"
20	16'-8"
20-5/8	17'-3"
21	17'-6"
22	18'-4"
22-1/2	18'-9"
23-3/8	19'-6"
24	20'-0"

For this reason, when it is necessary to drill vertical holes through a glulam member, the holes should be positioned in areas of the member that are stressed to less than 50% of design in bending. In a simply supported, uniformly loaded beam, this area would be located from the end of the beam inward approximately 1/8 of the beam span. In all cases, the minimum clear edge distance, as measured from either side of the member to the nearest edge of the vertical hole, should be 2-1/2 times the hole diameter. Use a drill guide to minimize “wandering” of the bit as it passes through knots or material of varying density, and to ensure a true alignment of the hole through the depth of the beam.

Holes for Support of Suspended Equipment

Heavy equipment or piping suspended from glulam beams should be attached such that load is applied to the top of the members to avoid tension perpendicular-to-grain stresses. Any horizontal holes required for support of significant weight, such as suspended heating and cooling units or main water lines, must be located above the neutral axis of the member and in a zone stressed to less than 50% of the design flexural stress (See Figure 3). Fasteners supporting light loads, such as light fixtures, must be placed at least four laminations or 25% of beam depth, whichever is greater, away from the tension face of the member. The design capacity of the beam should be checked for all such loads to ensure proper performance.

Protection of Field-Cut Notches and Holes

Frequently, glulam beams are provided from the manufacturer with the ends sealed by a protective coating. This sealer is applied to the end grain of the glulam beams to retard the migration of moisture in and out of the beam ends during transit and job site storage. Field cutting a notch in the end of a beam can change the moisture absorption characteristics of the beam at the notch location. This can result in seasoning checks or even localized splitting developing at the root of the notch. To minimize this possibility, all notches should be sealed immediately after cutting using a water-repellent sealer. Sealing other field-cut locations as well as field-drilled holes is also recommended. These sealers can be applied with a brush, swab, roller or spray gun.

Field Notching and Drilling of Glued Laminated Timber Beams

We have field representatives in many major U.S. cities and in Canada who can help answer questions involving APA trademarked products. For additional assistance in specifying engineered wood products, contact us:

APA HEADQUARTERS

7011 So. 19th St. ■ Tacoma, Washington 98466
(253) 565-6600 ■ Fax: (253) 565-7265

PRODUCT SUPPORT HELP DESK

(253) 620-7400 ■ help@apawood.org

DISCLAIMER

The information contained herein is based on APA – The Engineered Wood Association’s continuing programs of laboratory testing, product research, and comprehensive field experience. Neither APA, nor its members make any warranty, expressed or implied, or assume any legal liability or responsibility for the use, application of, and/or reference to opinions, findings, conclusions, or recommendations included in this publication. Consult your local jurisdiction or design professional to assure compliance with code, construction, and performance requirements. Because APA has no control over quality of workmanship or the conditions under which engineered wood products are used, it cannot accept responsibility for product performance or designs as actually constructed.

www.apawood.org

Form No. S560J/Revised February 2020

© 2020 APA – The Engineered Wood Association



REPRESENTING THE ENGINEERED WOOD INDUSTRY